

AUTOMOTIVE CURRENT TRANSDUCER OPEN LOOP TECHNOLOGY

HAH3DR 900-S03/SP4



Introduction

The HAH3DR-S03 family is a tri-phase transducer for DC, AC, or pulsed currents measurement in high power and low voltage automotive applications. It offers a galvanic separation between the primary circuit (high power) and the secondary circuit (electronic circuit).

The HAH3DR-S03 family gives you a choice of having different current measuring ranges in the same housing (from ± 200 up to ± 900 A).

Features

- Open Loop transducer using the Hall effect sensor
- Low voltage application
- Unipolar +5 V DC power supply
- Primary current measuring range up to ± 900 A
- Maximum RMS primary admissible current: defined by the busbar, the magnetic core or ASIC $T < +150$ °C
- Operating temperature range: -40 °C $< T < +125$ °C
- Output voltage: fully ratiometric (in sensitivity and offset).

Special feature

- Tri-phase transducer.

Advantages

- Excellent accuracy
- Very good linearity
- Very low thermal offset drift
- Very low thermal sensitivity drift
- High frequency bandwidth
- No insertion losses
- Very fast delay time.

Automotive applications

- Starter Generators
- Inverters
- HEV applications
- EV applications
- DC / DC converter.

Principle of HAH3DR S03 family

The open loop transducers uses a Hall effect integrated circuit. The magnetic flux density B , contributing to the rise of the Hall voltage, is generated by the primary current I_p to be measured.

The current to be measured I_p is supplied by a current source i.e. battery or generator (Figure 1).

Within the linear region of the hysteresis cycle, B is proportional to:

$$B(I_p) = a \times I_p$$

The Hall voltage is thus expressed by:

$$U_H = (c_H / d) \times I_H \times a \times I_p$$

Except for I_p , all terms of this equation are constant. Therefore:

$$U_H = b \times I_p$$

a constant

b constant

c_H Hall coefficient

d thickness of the Hall plate

I_H current across the Hall plates

The measurement signal U_H amplified to supply the user output voltage or current.

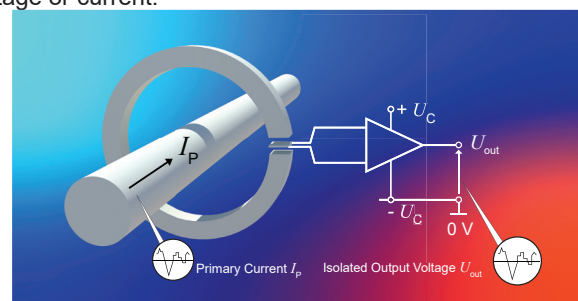
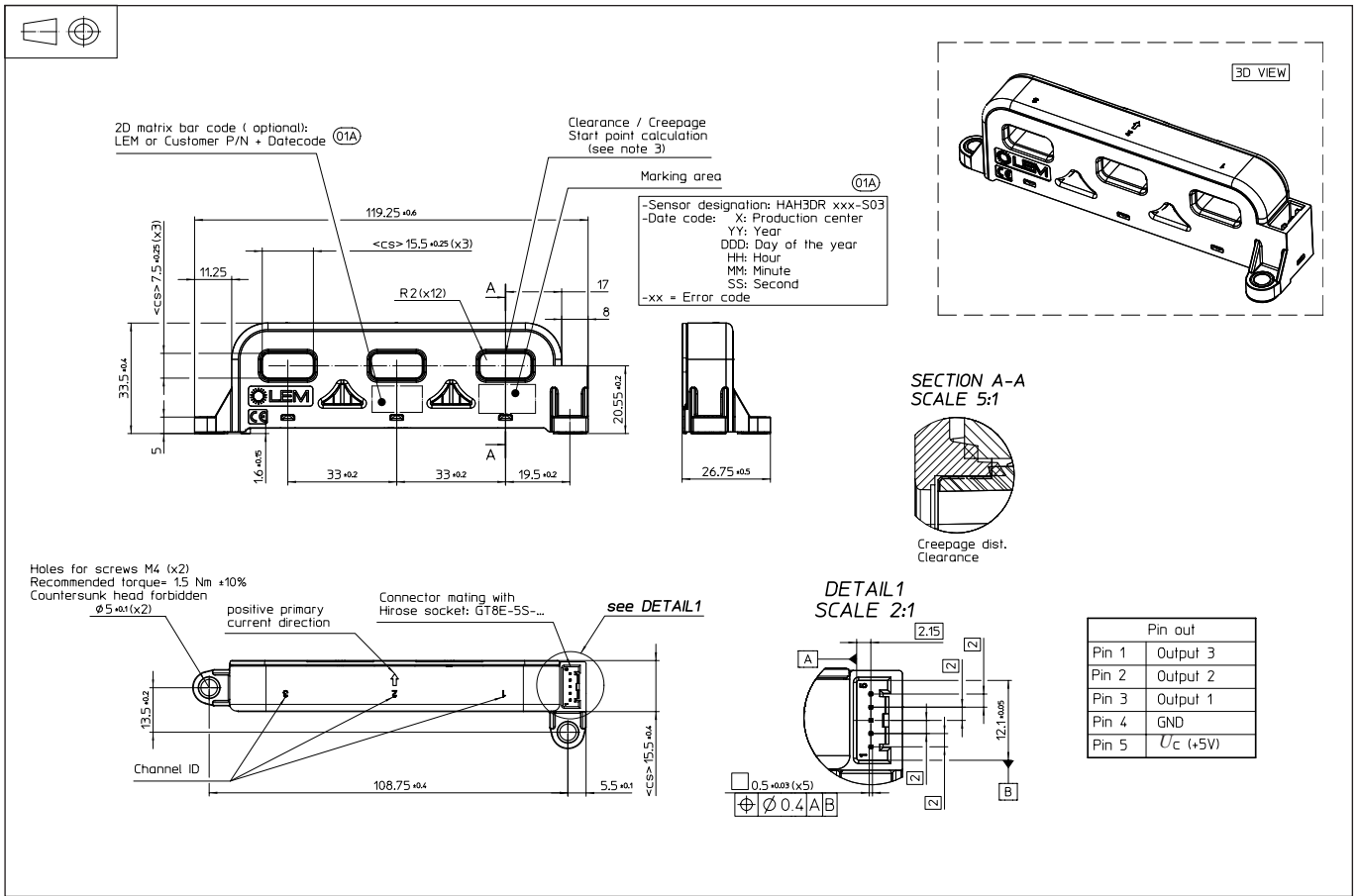

Fig. 1: Principle of the open loop transducer.

Dimensions (in mm)



Mechanical characteristics

- Plastic case >PBT-GF30< (natural)
- Magnetic core FeSi wound core
- Pins Copper alloy gold plated
- Mass 97 g $\pm 5\%$
- IP level IPxx.

Mounting recommendation

- Mating connector type Hirose Socket GT8E-5S-...
- Assembly torque max 1.5 N.m $\pm 10\%$
- The clamping force must be applied to the compression limiter, washer recommended.

$R_L > 10\text{ k}\Omega$ optional resistor for signal line diagnostic
 $C_L < 2.2\text{ nF}$ EMC protection
 RC: low pass filter (optional)

Remark

- $U_{out} > U_O$ when I_p flows in the positive direction (see arrow on drawing).

System architecture (example)

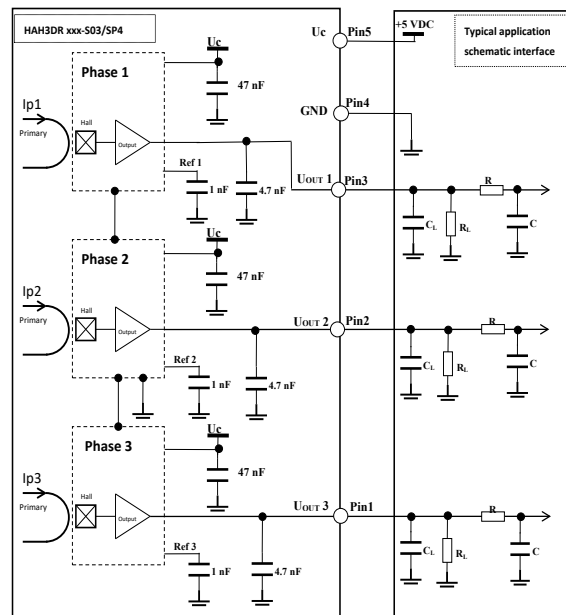

Absolute ratings (not operating)

Parameter	Symbol	Unit	Specification			Conditions
			Min	Typical	Max	
Maximum supply voltage	$U_{C\max}$	V	-0.5		8	Continuous not operating
					6.5	Exceeding this voltage may temporarily reconfigure the circuit until the next power on
Output voltage low ¹⁾	U_{outL}	V			0.2	@ $U_C = 5\text{ V}$, $T_A = 25\text{ °C}$
Output voltage high ¹⁾	U_{outH}	V	4.8			
Ambient storage temperature	T_{Ast}	°C	-50		125	
Electrostatic discharge voltage (HBM)	U_{ESD}	kV			2	JESD22-A114-B class 2
RMS voltage for AC insulation test	U_d	kV			2.5	50 Hz, 1 min, IEC 60664 part1
Creepage distance	d_{Cp}	mm	5.08			
Clearance	d_{Cl}	mm	5.08			
Comparative tracking index	CTI		PLC3			
Insulation resistance	R_{INS}	MΩ	500			500 V DC, ISO 16750
Primary nominal peak current	\hat{I}_{PN}	A				²⁾

Operating characteristics in nominal range (I_{PN})

Parameter	Symbol	Unit	Specification			Conditions
			Min	Typical	Max	
Electrical Data						
Primary current, measuring range	I_{PM}	A	-900		900	
Primary nominal RMS current	I_{PN}	A	-900		900	
Supply voltage ¹⁾	U_C	V	4.75	5	5.25	
Ambient operating temperature	T_A	°C	-40		125	
Load capacitance	C_L	nF			2.2	
Output voltage (Analog) ¹⁾	U_{out}	V	$U_{out} = (U_C/5) \times (U_o + S \times I_p)$			@ U_C
Sensitivity ¹⁾	S	mV/A		2.22		@ $U_C = 5\text{ V}$
Offset voltage	U_o	V		2.5		
Current consumption (for 3 phases)	I_C	mA		45	60	@ $U_C = 5\text{ V}$, @ $-40\text{ °C} < T_A < 125\text{ °C}$
Load resistance	R_L	KΩ	10			
Output internal resistance	R_{out}	Ω			10	DC to 1 kHz
Performance Data @ 3 Sigma (including phases coupling)						
Ratiometricity error	ϵ_r	%		0.5		
Sensitivity error	ϵ_S	%		±0.5		@ $T_A = 25\text{ °C}$
				±1		@ $T_A = 25\text{ °C}$, After T Cycles
Electrical offset voltage	U_{OE}	mV		±4		@ $T_A = 25\text{ °C}$, @ $U_C = 5\text{ V}$
Magnetic offset voltage @ $I_p = 0\text{ V}$	U_{OM}	mV	-7.5		7.5	@ $T_A = 25\text{ °C}$, @ $U_C = 5\text{ V}$
Average temperature coefficient of U_{OE}	TCU_{OEAV}	mV/°C	-0.08		0.08	@ $-40\text{ °C} < T_A < 125\text{ °C}$
Average temperature coefficient of S	TCS_{AV}	%/°C	-0.03	±0.01	0.03	@ $-40\text{ °C} < T_A < 125\text{ °C}$
Linearity error	ϵ_L	% I_p	-1		1	@ $U_C = 5\text{ V}$, @ $T_A = 25\text{ °C}$, @ $I = I_{PM}$
Delay time to 90 % of the final output value for I_{PN} step	t_{D90}	µs		4	6	$di/dt = 100\text{ A/µs}$
Frequency bandwidth ²⁾	BW	kHz	40			@ -3 dB
Peak-to-peak noise voltage	$U_{no pp}$	mV			10	@ DC to 1 MHz
Phase shift	$\Delta\phi$	°	-4		0	@ DC to 1 KHz

Notes: ¹⁾ The output voltage U_{out} , the offset voltage U_o , the sensitivity S and the output voltage low/high U_{outL+H} are fully ratiometric and dependant of the supply voltage U_C according the the following formula:

$$I_p = \left(\frac{5}{U_C} \times U_{out} - U_o \right) \times \frac{1}{S} \text{ with } S \text{ in (V/A)}$$

- ²⁾ Primary current frequencies must be limited in order to avoid excessive heating of the busbar, magnetic core and the ASIC (see feature paragraph in page 1).
³⁾ Transducer is not protected against reverse polarity.

Total error

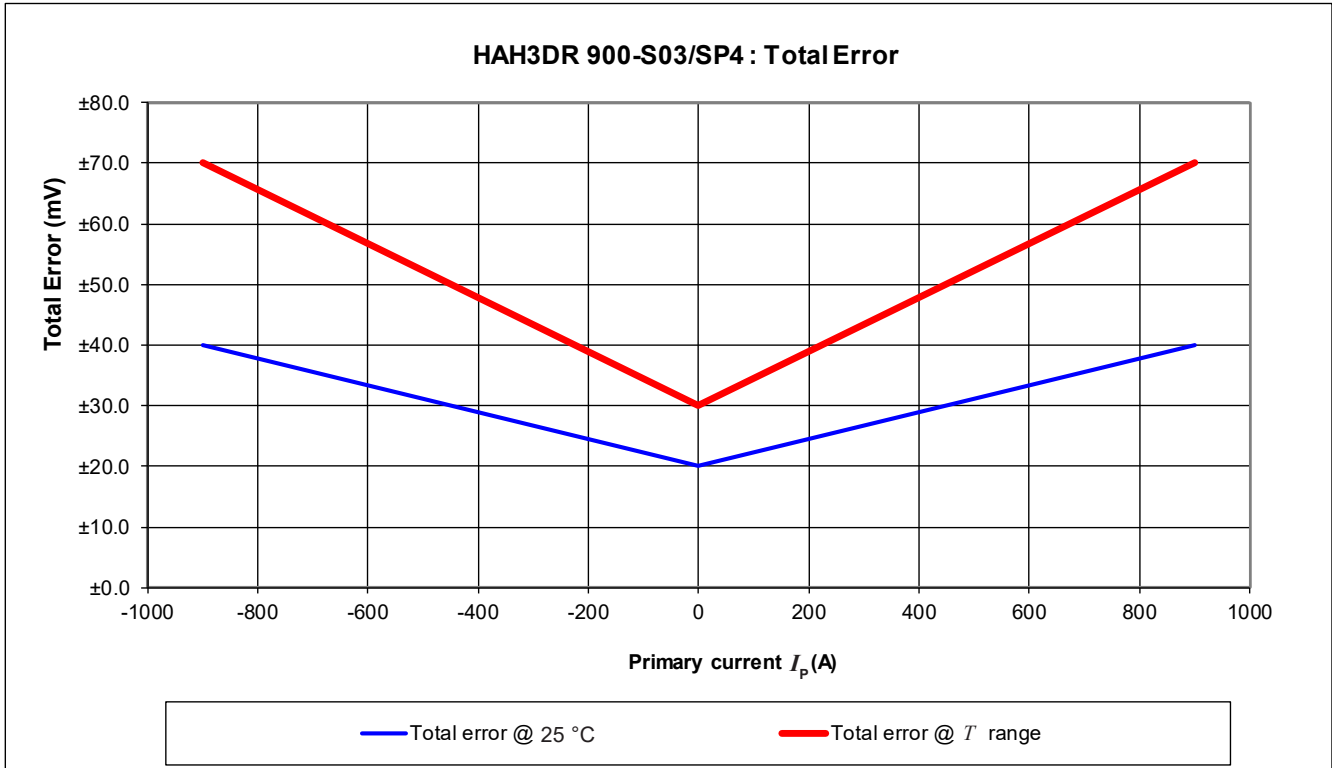

I_p (A)	Total error @ 25 °C (mV)			Total error @ T range (mV)		
	in mV	in A	in %	in mV	in A	in %
-900	±40.0	±18.0	±2.0	±70.0	±31.5	±3.50
0	±20.0	±9.0	±1.0	±30.0	±13.5	±1.50
900	±40.0	±18.0	±2.0	±70.0	±31.5	±3.50

PERFORMANCES PARAMETERS DEFINITIONS

Primary current definition:

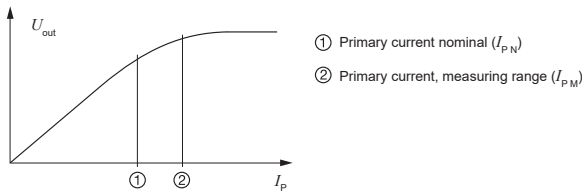

Definition of typical, minimum and maximum values:

Minimum and maximum values for specified limiting and safety conditions have to be understood as such as values shown in "typical" graphs. On the other hand, measured values are part of a statistical distribution that can be specified by an interval with upper and lower limits and a probability for measured values to lie within this interval. Unless otherwise stated (e.g. "100 % tested"), the LEM definition for such intervals designated with "min" and "max" is that the probability for values of samples to lie in this interval is 99.73 %. For a normal (Gaussian) distribution, this corresponds to an interval between -3 sigma and +3 sigma. If "typical" values are not obviously mean or average values, those values are defined to delimit intervals with a probability of 68.27 %, corresponding to an interval between -sigma and +sigma for a normal distribution. Typical, minimum and maximum values are determined during the initial characterization of a product.

Output noise voltage:

The output voltage noise is the result of the noise floor of the Hall elements and the linear amplifier.

Magnetic offset:

The magnetic offset is the consequence of an any current on the primary side. It's defined after a stated excursion of primary current.

Linearity:

The maximum positive or negative discrepancy with a reference straight line $U_{out} = f(I_p)$.
Unit: linearity (%) expressed with full scale of $I_{p,N}$.

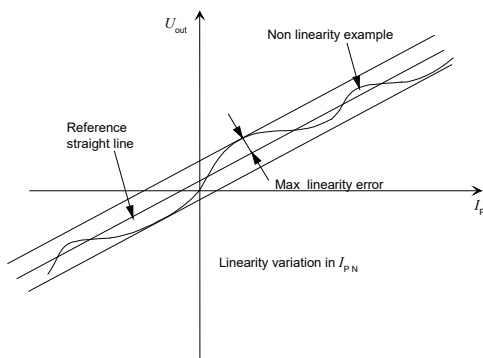

Delay time t_{D90} :

The time between the primary current signal ($I_{p,N}$) and the output signal reach at 90 % of its final value.

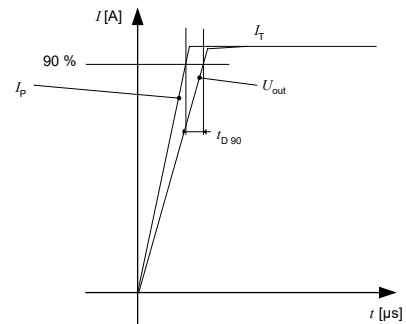

Sensitivity:

The transducer's sensitivity S is the slope of the straight line $U_{out} = f(I_p)$, it must establish the relation:

$$U_{out}(I_p) = U_c/5 (S \times I_p + U_o)$$

Offset with temperature:

The error of the offset in the operating temperature is the variation of the offset in the temperature considered with the initial offset at 25 °C.

The offset variation I_{OT} is a maximum variation the offset in the temperature range:

$$I_{OT} = I_{OE \max} - I_{OE \min}$$

The offset drift TCI_{OEAV} is the I_{OT} value divided by the temperature range.

Sensitivity with temperature:

The error of the sensitivity in the operating temperature is the relative variation of sensitivity with the temperature considered with the initial offset at 25 °C.

The sensitivity variation S_T is the maximum variation (in ppm or %) of the sensitivity in the temperature range:
 $S_T = (Sensitivity \max - Sensitivity \min) / Sensitivity \text{ at } 25 \text{ °C}$.

The sensitivity drift TCS_{AV} is the S_T value divided by the temperature range. Deeper and detailed info available is our LEM technical sales offices (www.lem.com).

Offset voltage @ $I_p = 0$ A:

The offset voltage is the output voltage when the primary current is zero. The ideal value of U_o is $U_c/2$. So, the difference of $U_o - U_c/2$ is called the total offset voltage error. This offset error can be attributed to the electrical offset (due to the resolution of the ASIC quiescent voltage trimming), the magnetic offset, the thermal drift and the thermal hysteresis. Deeper and detailed info available is our LEM technical sales offices (www.lem.com).

Environmental test specifications:

Refer to LEM GROUP test plan laboratory CO.11.11.515.0 with "Tracking_Test Plan_Auto" sheet.

Environmental test specifications:

Name	Standard	Conditions
Electrical tests		
Phase delay check	LEM Procedure	100 Hz to 100 kHz @ 50 A peak
Noise measurement	LEM Procedure	Sweep from DC to 1 MHz
Delay time di/dt	LEM Procedure	100 A/ μ s, I pulse = 900 A
dv/dt	LEM Procedure	> 5 kV/ μ s, U = 1000 V
Dielectric Withstand Voltage test	ISO 16750-2 §4.11 §4.12	2500 V AC / 1 min / 50 Hz
Insulation resistance	ISO 16750-2 (2010)	500 V DC, time = 60 s $R_{INS} \geq 500 M\Omega$ minimum
Environmental tests		
High $T^{\circ}C$, High Humidity, Electrical connection	IEC 60068-2-78 (2001)	1000 hours +85 $^{\circ}C$ /85 % RH $U_C = 5$ V DC, $I_p = 0$
Thermal Shock	ISO 16750-4 §5.3.2 (04.2010)	1000 cycles (1000 hours), 30 min @ -40 $^{\circ}C$ // 30 min @ +125 $^{\circ}C$ U_C not connected, $I_p = 0$
High $T^{\circ}C$ Storage + High $T^{\circ}C$ Exposure	ISO 16750-4 §5.1.2.1 (04.2010)	Storage: 125 $^{\circ}C$ for 1000 hours U_C not connected, $I_p = 0$ for both tests
Mechanical Shock	ISO 16750-3 §4.2.2 (12.2012)	50 g/6 ms Half Sine @ 25 $^{\circ}C$ 10 shocks of each direction (Total: 60) U_C not connected, $I_p = 0$
Random Vibration in $T^{\circ}C$	ISO 16750-3 §4.1.2.4 (12.2012)	Profile1: 22 h/axe, 10 Hz - 2000 Hz Profile2: 8 h/axe, 10 Hz - 2000 Hz
EMC tests		
Radiated Emission Absorber Lined Shielded Enclosure (ALSE)	CISPR 25	0.15 MHz to 2500 MHz Limit: CISPR 25 (ed3.0) Class 5 Peak (table 9)
Radiated Immunity Bulk Current Injection (BCI)	GMW3097 (2006) §3.4.1 ISO 11452-1 & - 4	1 MHz to 400 MHz Level: Level 2 (table 11)
Radiated Immunity Anechoic chamber	GMW3097 (2006) §3.4.2 ISO 11452-1 & - 2	400 MHz to 2000 MHz Level: Level 2 (table 12)
ESD Test	GMW3097 (2006) §3.6.3	150 pF / 2000 Ω Contact: ± 4 kV, ± 6 kV Air: ± 8 kV U_C not connected

Random Vibration Profile 1 $-40\text{ °C} < T < 125\text{ °C}$

Hz	PSD [(m/s ²) ² /Hz]
Frequency	Profile 1
10	10
100	10
300	0.51
500	5
1000	5
2000	5

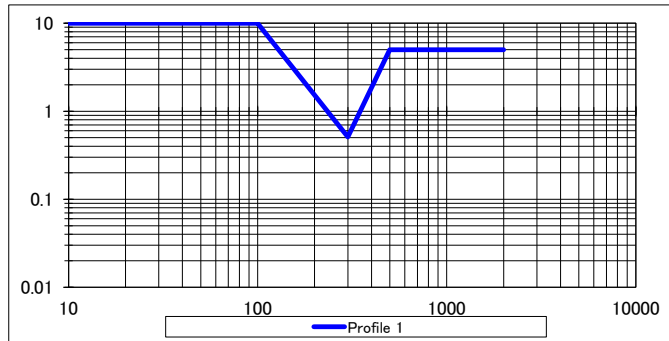

Random Vibration Profile 2 $-40\text{ °C} < T < 125\text{ °C}$

Hz	PSD [(m/s ²) ² /Hz]
Frequency	Profile 2
20	200
40	200
300	0.5
800	0.5
1000	3
2000	3

