

SCOPE

This specification describes PA0100 to 2010 series current sensor - low TCR with metal substrate.

APPLICATIONS

- Smart Phone
- Batteries
- Computer
- Telecom / Datacom
- Industrial / Power supply
- Car electronics

FEATURES

- AEC-Q200 qualified
- Halogen-free Epoxy
- Total lead free without RoHS exemption
- RoHS compliant
- Reduce environmentally hazardous wastes
- High component and equipment reliability
- Non-forbidden materials used in products/production
- Low resistances applied to current sensing
- Moisture sensitivity level: MSL 1

ORDERING INFORMATION - GLOBAL PART NUMBER

Global part numbers are identified by the series, size, tolerance, packing type, temperature coefficient, taping reel and resistance value.

GLOBAL PART NUMBER

PA XXXX X X X XX XXXX X
 (1) (2) (3) (4) (5) (6) (7)

(1) SIZE

0100/0201/0402/0603/0805/1206/2010

(2) TOLERANCE

D = ±0.5%
 F = ±1%
 J = ±5%

(3) PACKAGING TYPE

R = Paper taping reel (PA0100~PA1206)
 K = Embossed taping reel (PA2010)

(4) TEMPERATURE COEFFICIENT OF RESISTANCE

E = ± 50ppm/°C
 M = ± 75ppm/°C
 F = ± 100ppm/°C
 L = ± 150ppm/°C
 G = ± 200ppm/°C
 I = ± 300ppm/°C

(5) TAPING REEL

07 / 7W / 7T / 47 / 57 / 87 inch dia. Reel and specific rated power
 Detailed power rating are shown in the Table 2.

(6) RESISTANCE VALUE

1 mΩ to 20 mΩ

(7) DEFAULT CODE

Letter L / Z is the system default code for ordering only. ^(Note)
 L is for 0100/0201/0402/0603/0805
 Z is for only 1206/2010

Resistance rule of global part number	
Resistance code rule	Example
0RXXX	0R001 = 1 mΩ
(1 to 20 mΩ)	0R02 = 20 mΩ

ORDERING EXAMPLE

The ordering code for a PA0805
 0.125W chip resistor,TC50 value 0.01Ω
 (10mR) with ±1% tolerance, supplied in
 7-inch tape reel with 5Kpcs quantify is:
 PA0805FRE070R01L.

NOTE

1. All our RChip products are RoHS compliant. "LFP" of the internal 2D reel label mentions "Lead-Free Process"

MARKING

PA0100/0201/0402/0603/0805/1206/2010



CONSTRUCTION

The resistors are constructed using outstanding TCR level materials, which make Yageo PA resistors excellent for current sensing application in battery charger circuit & DC-DC converter.

The advanced resistive materials are adopted to get the precisely required resistance.

Finally, the three materials of external terminations (Cu / Ni / matte Tin) are added, as shown in Fig. 2.

Outlines

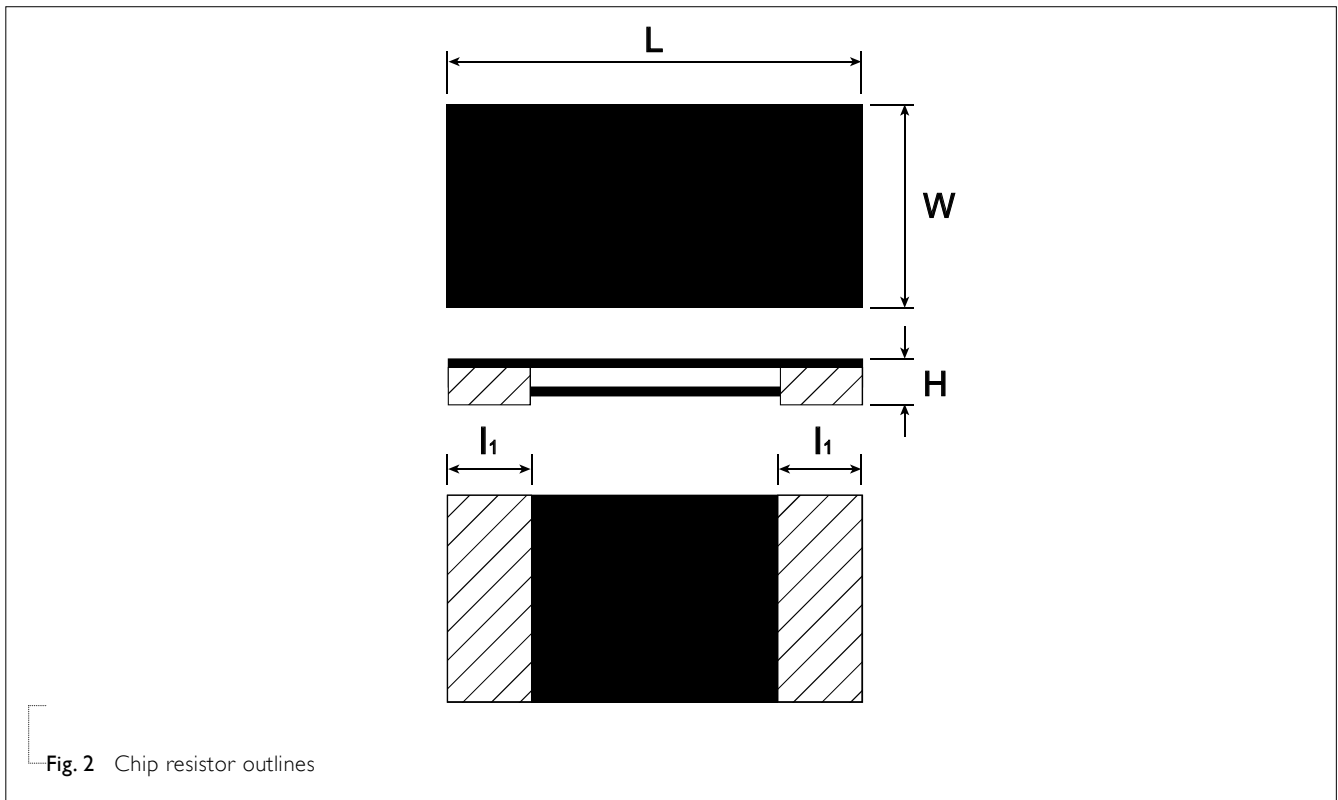

Fig. 2 Chip resistor outlines

DIMENSION

Table 1 For outlines, please refer to Fig. 2

TYPE	RESISTANCE RANGE	L (mm)	W (mm)	H (mm)	ll (mm)
PA0100	10mΩ ≤ R ≤ 20mΩ	0.40±0.03	0.20±0.03	Max. 0.15	0.10±0.03
PA0201	5mΩ ≤ R ≤ 20mΩ	0.60±0.03	0.31±0.04	Max. 0.30	0.15±0.06
PA0402	2mΩ ≤ R ≤ 20mΩ	1.00±0.10	0.55±0.10	Max. 0.40	0.25±0.10
PA0603	1 mΩ	1.60±0.20	0.80±0.20	0.55±0.15	0.38±0.12
	2mΩ	1.60±0.20	0.80±0.20	0.45±0.15	0.38±0.12
	2.5mΩ ≤ R ≤ 20mΩ	1.60±0.20	0.80±0.20	0.30±0.15	0.38±0.12
PA0805	1mΩ	2.03±0.20	1.27±0.20	0.55±0.15	0.60±0.15
	1.5/ 2mΩ	2.03±0.20	1.27±0.20	0.45±0.15	0.50±0.15
	2.5mΩ ≤ R ≤ 20mΩ	2.03±0.20	1.27±0.20	0.30±0.15	0.35±0.20
PA1206	1mΩ	3.20±0.25	1.60±0.25	0.65±0.25	0.51±0.25
	2mΩ	3.20±0.25	1.60±0.25	0.55±0.25	0.60±0.25
	2.5/ 3mΩ	3.20±0.25	1.60±0.25	0.40±0.25	0.80±0.30
	4mΩ ≤ R ≤ 20mΩ	3.20±0.25	1.60±0.25	0.40±0.25	0.60±0.30
PA2010	1mΩ ≤ R ≤ 3mΩ	5.08±0.25	2.54±0.25	0.50±0.25	1.40±0.25
	4mΩ ≤ R ≤ 20mΩ	5.08±0.25	2.54±0.25	0.40±0.25	0.70±0.25

Note:

1. For relevant physical dimensions, please refer to construction outlines.
2. Please contact with sales offices, distributors and representatives in your region before ordering.

ELECTRICAL CHARACTERISTICS

Table 2 POWER RATING⁽⁴⁾ @ 70°C

SIZE	POWER RATING ⁽⁴⁾ @ 70°C						TOLERANCE ⁽²⁾	RESISTANCE RANGE	TEMPERATURE COEFFICIENT OF RESISTANCE ⁽³⁾	
	07	7W	7T	47	57	87				
0100	1/32W	1/16W	--	--	--	--	±1%(F) ±5%(J)	10mΩ ≤ R ≤ 20mΩ	±300 ppm/°C(I)	
0201	1/20W	1/10W	3/20W	1/4W	--	--	±0.5%(D)	20mΩ	±150 ppm/°C(L)	
							±1%(F) ±5%(J)	5mΩ ≤ R ≤ 20mΩ		
0402	1/16W	1/8W	1/6W	1/4W	1/3W	--	±0.5%(D)	15mΩ ≤ R ≤ 20mΩ	±150 ppm/°C(L)	
							±1%(F) ±5%(J)	2mΩ ≤ R ≤ 20mΩ		
0603	1/10W	1/5W	1/3W	2/5W	1/2W	--	±0.5%(D)	10mΩ ≤ R ≤ 20mΩ	1mΩ	
							±1%(F) ±5%(J)	1mΩ ≤ R ≤ 20mΩ	2/2.5mΩ	±200 ppm/°C(G)
									3mΩ ≤ R ≤ 20mΩ	±50 ppm/°C(E), ±75 ppm/°C(M)
0805	1/8W	1/4W	--	1/2W	--	1W	±0.5%(D)	10mΩ ≤ R ≤ 20mΩ	1/1.5mΩ	
							±1%(F) ±5%(J)	1mΩ ≤ R ≤ 20mΩ	2mΩ ≤ R ≤ 20mΩ	±150 ppm/°C(L) ±50 ppm/°C(E)
1206	1/4W	1/2W	--	1W	--	--	±0.5%(D)	5mΩ ≤ R ≤ 20mΩ	1/2mΩ	
							±1%(F) ±5%(J)	1mΩ ≤ R ≤ 20mΩ	3mΩ ≤ R ≤ 20mΩ	±100 ppm/°C(F) ±50 ppm/°C(E)
2010	1/2W	1W	3/2W	2W	--	--	±0.5%(D)	5mΩ ≤ R ≤ 20mΩ	±50 ppm/°C(E)	
							±1%(F) ±5%(J)	(2W : 5mΩ ≤ R ≤ 10mΩ)		
								(2W : 1mΩ ≤ R ≤ 10mΩ)		

Note: 1. Please contact with sales offices, distributors and representatives in your region before ordering.

2. Global part number (code7)
3. Global part number (code9)
4. Global part number (code10-11)

FUNCTIONAL DESCRIPTION

OPERATING TEMPERATURE RANGE

PA0100 to PA0402 Range: -55°C to +125°C

PA0603/ 0805 Range: -55°C to +155°C

PA1206/ 2010 Range: -55°C to +170°C

POWER RATING

Standard rated power at 70°C: For detail power value, please refer to Table 2.

RATED VOLTAGE

The DC or AC (rms) continuous working voltage corresponding to the rated power is determined by the following formula:

$$V = \sqrt{(P \times R)}$$

Where

V = Continuous rated DC or AC (rms) working voltage (V)

P = Rated power (W)

R = Resistance value (Ω)

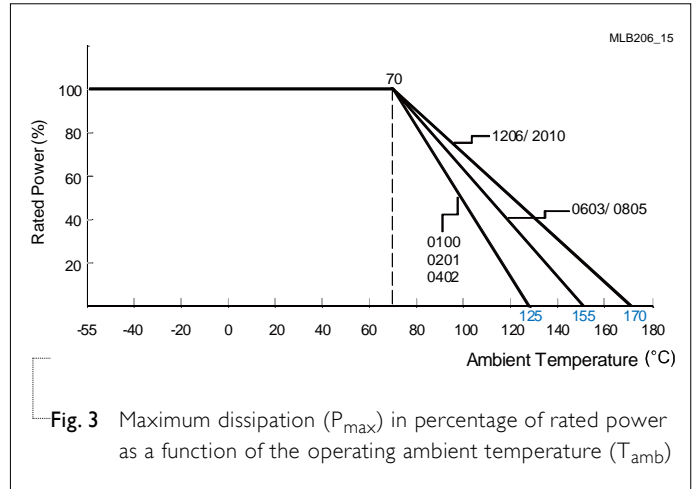

PACKING STYLE AND PACKAGING QUANTITY

Table 3 Packing style and packaging quantity

PACKING STYLE	REEL DIMENSION	PA0100	PA0201	PA0402	PA0603	PA0805	PA1206	PA2010
Paper Taping Reel (R)	7" (178 mm)	20,000	10,000	10,000	5,000	5,000	4,000	-
Embossed Taping Reel (K)	7" (178 mm)	-	-	-	-	-	-	4,000

PAPER TAPE

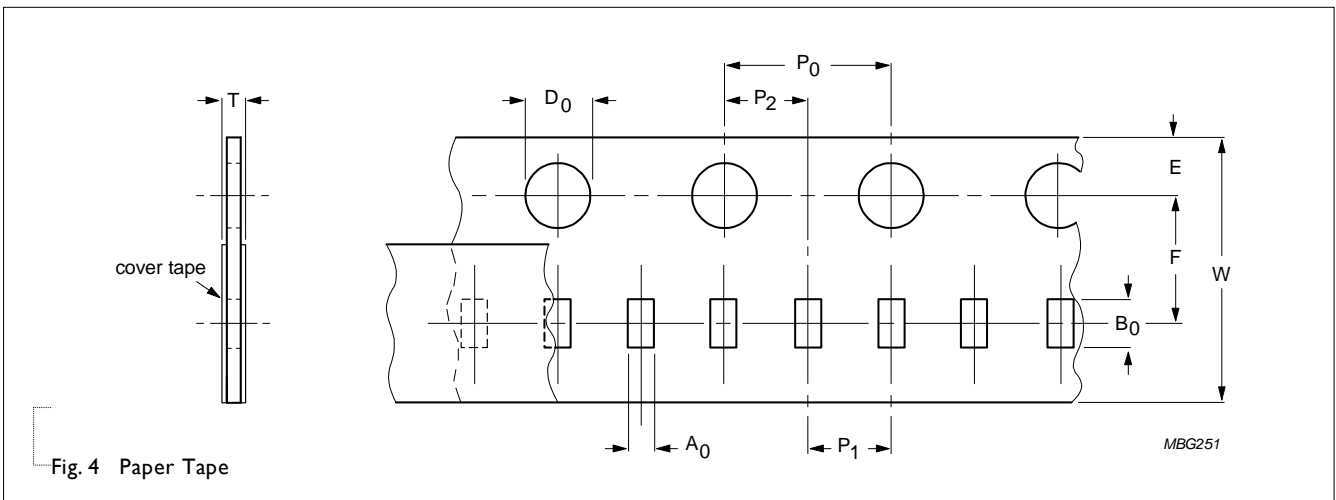

EMBOSSED TAPE

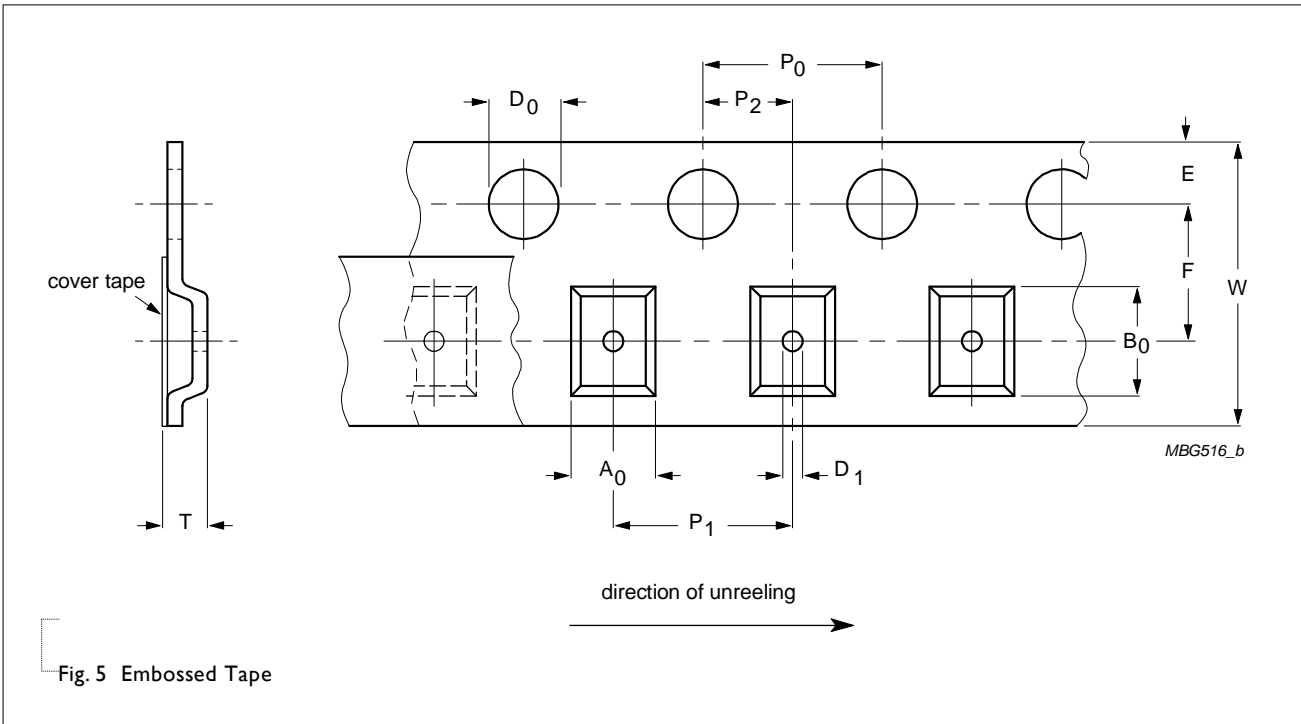

Fig. 5 Embossed Tape

Table 4 Dimensions of paper tape for relevant chip resistors size

SIZE	SYMBOL										Unit: mm
	A ₀	B ₀	W	E	F	P ₀	P ₁	P ₂	ΦD ₀	T	
PA0100	0.24±0.03	0.45±0.03	8.00±0.20	1.75±0.10	3.50±0.05	4.00±0.05	2.00±0.10	2.00±0.05	1.50±0.10	0.31±0.10	
PA0201	0.39±0.10	0.70±0.10	8.00±0.30	1.75±0.10	3.50±0.10	4.00±0.10	2.00±0.10	2.00±0.10	1.55±0.05	0.43±0.10	
PA0402	0.59±0.10	1.10±0.10	8.00±0.30	1.75±0.10	3.50±0.10	4.00±0.10	2.00±0.10	2.00±0.10	1.55±0.05	0.53±0.10	
PA0603	1.08±0.10	1.90±0.10	8.00±0.30	1.75±0.10	3.50±0.10	4.00±0.10	4.00±0.10	2.00±0.10	1.55±0.05	0.60±0.10	
PA0805	1.60±0.10	2.35±0.10	8.00±0.30	1.75±0.10	3.50±0.10	4.00±0.10	4.00±0.10	2.00±0.10	1.55±0.05	0.60±0.10 ⁽¹⁾	
	1.60±0.10	2.35±0.10	8.00±0.30	1.75±0.10	3.50±0.10	4.00±0.10	4.00±0.10	2.00±0.10	1.55±0.05	0.53±0.10 ⁽²⁾	
PA1206	1.90±0.10	3.50±0.10	8.00±0.30	1.75±0.10	3.50±0.10	4.00±0.10	4.00±0.10	2.00±0.10	1.55±0.05	0.85±0.15	

Note: 1. $1\text{m}\Omega \leq R \leq 2\text{m}\Omega$ (T = 0.60± 0.10mm)
 2. $2.5\text{m}\Omega \leq R \leq 20\text{m}\Omega$ (T = 0.53± 0.10mm)

Table 5 Dimensions of embossed tape for relevant chip resistors size

SIZE	SYMBOL										Unit: mm
	A ₀	B ₀	W	E	F	P ₀	P ₁	P ₂	ΦD ₀	T	
PA2010	3.40±0.15	6.70±0.15	12.0±0.30	1.75±0.10	5.50±0.10	4.00±0.10	4.00±0.10	2.00±0.10	1.55±0.10	0.85±0.15	

REEL SPECIFICATION

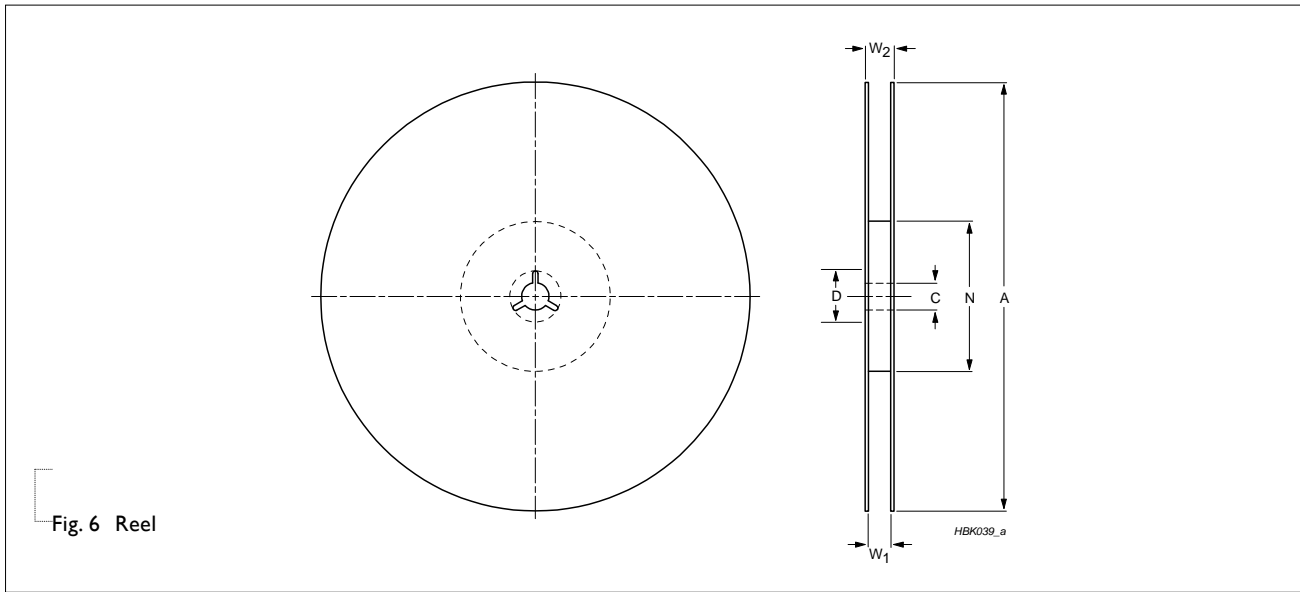

Table 6 Dimensions of reel specification for relevant chip resistors size

SIZE	QUANTITY PER REEL	REEL SIZE		SYMBOL				
		8mm TAPE WIDE	12mm TAPE WIDE	A	N	C	D	W ₁
PA0100	20,000	7" (Φ178mm)	-	180.0+0/-3.0	60.0+1/-0	13.00±0.2	21.0±0.8	9.0±0.3
PA0201	10,000	7" (Φ178mm)	-	178.0±1.0	60.0+1/-0	13.50±0.5	21.0±0.8	9.0±0.5
PA0402	10,000	7" (Φ178mm)	-	178.0±1.0	60.0+1/-0	13.50±0.5	21.0±0.8	9.0±0.5
PA0603	5,000	7" (Φ178mm)	-	178.0±1.0	60.0+1/-0	13.50±0.5	21.0±0.8	9.0±0.5
PA0805	5,000	7" (Φ178mm)	-	178.0±1.0	60.0+1/-0	13.50±0.5	21.0±0.8	9.0±0.5
PA1206	4,000	7" (Φ178mm)	-	178.0±1.0	60.0+1/-0	13.50±0.5	21.0±0.8	9.0±0.5
PA2010	4,000	-	7" (Φ178mm)	178.0±1.0	60.0+1/-0	13.50±0.5	21.0±0.8	13.6±0.5

LEADER/TRAILER TAPE SPECIFICATION

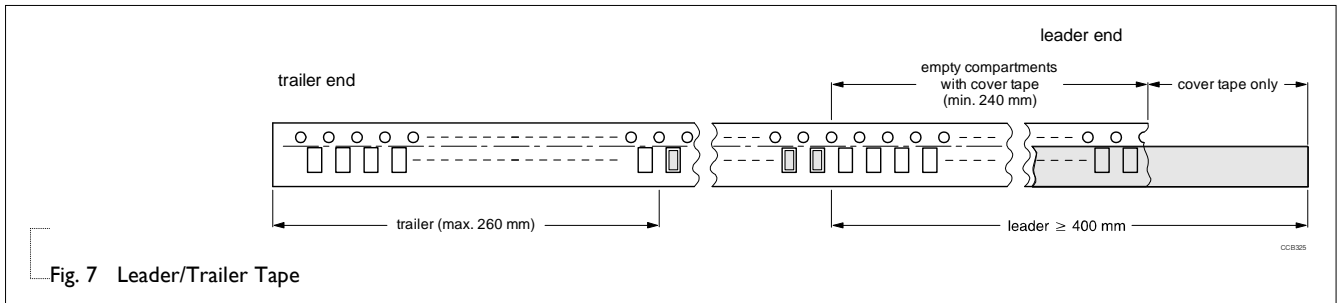

Fig. 7 Leader/Trailer Tape

FOOTPRINT AND SOLDERING PROFILES

For recommended soldering profiles, please refer to data sheet “Chip resistors mounting”.

FOOTPRINT

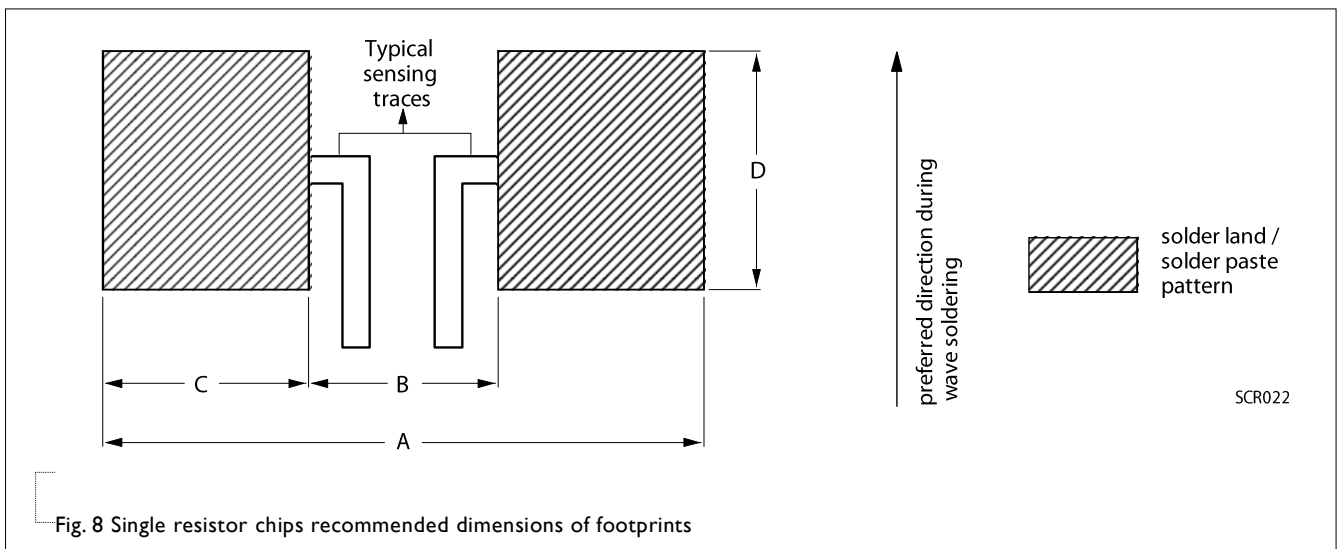

Fig. 8 Single resistor chips recommended dimensions of footprints

Table 7 Footprint dimensions

TYPE	RESISTANCE RANGE	A	B	C	D	Unit: mm
PA0100	$10\text{m}\Omega \leq R \leq 20\text{m}\Omega$	0.5~0.8	0.16~0.2	0.17~0.3	0.2~0.4	
PA0201	$5\text{m}\Omega \leq R \leq 20\text{m}\Omega$	1.00	0.30	0.35	0.40	
PA0402	$2\text{m}\Omega \leq R \leq 20\text{m}\Omega$	2.00	0.40	0.80	0.60	
PA0603	$1\text{m}\Omega$	2.20	0.50	0.70	0.90	
	$1\text{m}\Omega < R \leq 20\text{m}\Omega$	2.20	0.80	0.70	0.90	
PA0805	$1\text{m}\Omega$	4.10	0.50	1.80	1.44	
	$1.5\text{m}\Omega \leq R \leq 20\text{m}\Omega$	4.60	1.00	1.80	1.44	
PA1206	$1\text{m}\Omega / 2\text{m}\Omega$	4.20	1.00	1.60	1.84	
	$2.5\text{m}\Omega / 3\text{m}\Omega$	4.80	1.00	1.90	1.84	
	$4\text{m}\Omega \leq R \leq 20\text{m}\Omega$	4.80	1.20	1.80	1.84	
PA2010	$1\text{m}\Omega \leq R \leq 3\text{m}\Omega$	6.00	1.40	2.30	3.00	
	$4\text{m}\Omega \leq R \leq 20\text{m}\Omega$	6.00	3.50	1.25	3.00	

TESTS AND REQUIREMENTS

Table 8 Test condition, procedure and requirements

TEST	TEST METHOD	PROCEDURE	REQUIREMENT
Short time overload	IEC60115-1 4.13	5 times of rated power for 5 seconds at room temperature	0100 : $\pm(2.0\%+0.0005\Omega)$ Others : $\pm(1.0\%+0.0005\Omega)$ No visible damage
High Temperature Exposure/ Endurance at Upper Category Temperature	MIL-STD-202G-Method 108	1,000 hours at maximum operating temperature depending on specification, unpowered No direct impingement of forced air to the parts Tolerances: 0100/0201/0402: $125\pm 3^{\circ}\text{C}$ 0603/0805: $155\pm 3^{\circ}\text{C}$ 1206/2010: $170\pm 3^{\circ}\text{C}$	0100 : $\pm(3.0\%+0.0005\Omega)$ Others : $\pm(1.0\%+0.0005\Omega)$
Temperature Cycling	JESD22-A104	1,000 cycles, $-55/+125^{\circ}\text{C}$ for 1 cycle per hour	$\pm(1.0\%+0.0005\Omega)$
Moisture Resistance	MIL-STD-202G-Method 106	Each temperature / humidity cycle is defined at 8 hours (method 106F), 3 cycles / 24 hours for 10d with $25^{\circ}\text{C} / 65^{\circ}\text{C}$ 95% R.H, without steps 7a & 7b, unpowered	0100 : $\pm(3.0\%+0.0005\Omega)$ Others : $\pm(0.5\%+0.0005\Omega)$
Biased Humidity	MIL-STD-202 Method 103	1,000 hours; $85^{\circ}\text{C} / 85\%$ RH 10% of operating power	0100 : $\pm(3.0\%+0.0005\Omega)$ Others : $\pm(1.0\%+0.0005\Omega)$
Operational Life/ Endurance	MIL-STD-202G-Method 108 IEC 60115-1 4.25.1	1,000 hours at $125\pm 3^{\circ}\text{C}$, de-rated power applied for 1.5 hours on, 0.5 hour off, still-air required 1,000 hours at $70\pm 2^{\circ}\text{C}$ applied rated power 1.5 hours on, 0.5 hour off, still air required	0100 : $\pm(3.0\%+0.0005\Omega)$ others $\pm(1.0\%+0.0005\Omega)$
Resistance to Solvents	MIL-STD-202 Method 215	Immerse in isopropyl alcohol for 5 min with ultrasonic at room temperature	No visible damage
Mechanical Shock	MIL-STD-202 Method 213	Three shocks in each direction shall be applied along the three mutually perpendicular axes of the test specimen. Peak value: 100 g's Duration: 6 ms Velocity change: 12.3 ft/s Waveform: Half sine	0100 : $\pm(1.0\%+0.0005\Omega)$ Others : $\pm(0.5\%+0.0005\Omega)$
Vibration	MIL-STD-202 Method 204	5 g's for 20 min., 12 cycles each of 3 orientations Test from 10-2000 Hz.	0100 : $\pm(1.0\%+0.0005\Omega)$ Others : $\pm(0.5\%+0.0005\Omega)$
Resistance to Soldering Heat	MIL-STD-202G-method 210	Condition B, no pre-heat of samples Leadfree solder, 260°C , 10 seconds immersion time Procedure 2 for SMD: devices fluxed and cleaned with isopropanol	0100 : $\pm(1.0\%+0.0005\Omega)$ Others : $\pm(0.5\%+0.0005\Omega)$ No visible damage

TEST	TEST METHOD	PROCEDURE	REQUIREMENT
Thermal Shock	MIL-STD-202 Method 107	-55/+125°C, Number of cycles is 300. Maximum transfer time is 20 seconds. Dwell time is 15 minutes. Air -Air	±(1.0%+0.0005Ω) No visible damage
Electrostatic Discharge	AEC-Q200-002	Human Body Model, 1 pos + 1 neg. 0805/ 1206/ 2010 : 2KV 0402/ 0603 : 1KV 0100/ 0201: 500V	±(1.0%+0.0005Ω) No visible damage
Solderability - Wetting	J-STD-002	0201 to 2010 : (a) Method B, aging 4 hours at 155°C dry heat, dipping at 235±3°C for 5±0.5 seconds. (b) Method B, steam aging 8 hours, dipping at 215±3°C for 5±0.5 seconds. (c) Method D, steam aging 8 hours, dipping at 260±3 °C for 30±0.5 seconds. 0100 : 1st step: Method B, aging 4 hours at 155°C dry heat. 2nd step: Lead-free solder bath at 245±3°C, dipping at 245±3°C for 3±0.5 seconds	Well tinned (>95% covered) No visible damage
Flammability	UL94	Try to inflame a specimen by a needle flame	No ignition of specimen;V-0
Board Flex / Bending	AEC-Q200-005	Chips mounted on a 90mm glass epoxy resin PCB (FR4), Bending for 0100: 5mm 0201: 3mm 0402 and above: 2mm Holding time: Min.60 seconds	±(1.0%+0.0005Ω)
Terminal Strength (SMD)	AEC-Q200-006	Applied 0100: 0.98N 0201: 3N 0402: 5N 0603/ 0805/ 1206/ 2010: 17.7N for 60±1 seconds.	±(1.0%+0.0005Ω) No visible damage
Flame Retardance	AEC-Q200-001	Apply voltage to increase the surface temp to 350°C	No flame, no explosion
Temperature Coefficient of Resistance (T.C.R.)	IEC 60115-1 4.8	At +25/+125°C Formula: $T.C.R = \frac{R_2 - R_1}{R_1(t_2 - t_1)} \times 10^6 \text{ (ppm/°C)}$ Where t1 =+25°C or specified room temperature t2 =+125°C test temperature R1 =resistance at reference temperature in ohms R2=resistance at test temperature in ohms	Refer to table 2

REVISION HISTORY

REVISION	DATE	CHANGE NOTIFICATION	DESCRIPTION
Version 1	Jun. 10, 2021	-	- Add size of PA0100 and tol. $\pm 0.5\%$ for 0201/0402/0603/2010
Version 0	May 07, 2020	-	- New datasheet for automotive grade current sensor – PA0201/0402/0603/0805/1206/2010 series.